

TWO-STAGE SPRING-LOADED PRESSURE REGULATORS

R/25 SERIES

- Internal relief valve
- Overpressure slam-shut valve
- Underpressure slam-shut valve
- Gas failure slam-shut valve
- Maximum capacity slam-shut valve
- Manual reset
- Ease of installation
- Wide range of applications
- Working pressure up to 5 bar
- Capacity up to 25 St.cu.m/h
- Built to UNI-CIG 8827 Standards

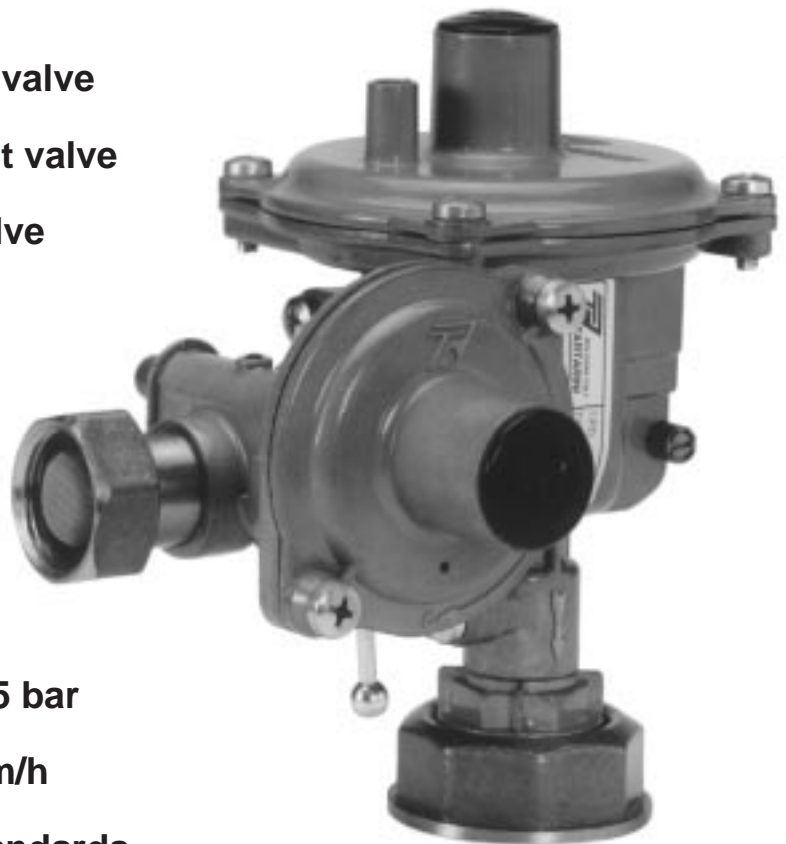

The **R/25 Series** two-stage pressure regulators are designed for use in a wide range of both domestic and industrial applications and can also be mounted in individual domestic gas systems and meters.

These regulators can be employed with natural gas, manufactured gas, air, propane and other gases as long as these do not contain a high percentage of benzol.

Their main features include compact size for space saving, high-quality materials, high regulation accuracy, easy setting and maximum reliability of safety devices. Their trouble-free operation is ensured in all mounting positions.

Moreover, the regulators in this series can also be installed both outdoors (working temperature range -20 to +60°C) and indoors as highly sensitive safety devices ensure release of gas to atmosphere in case of overpressure.

CONSTRUCTION FEATURES

The **R/25 Series** includes two-stage, spring-loaded regulators.

Regulators in this series come in two models which differ in the type of inlet connection seal, i.e.:

R/25 model with soft seal

R/25-1 model with metal-to-metal seal.

In accordance with UNI-CIG 8827 Standards, these regulators are provided with overpressure and underpressure slam-shut valves as well as with an internal relief valve designed to shut-off gas flow upon maximum admissible capacity being exceeded.

OPERATION

The gas at working pressure (max 5 bar) initially flows to the inlet connection, then through the filter and onto the first stage where pressure is reduced to 0.2 bar. Gas is subsequently conveyed to the second stage where pressure is reduced to the desired value.

The first-stage regulator includes a diaphragm (D1), a spring (M1) and a valve (O1). Gas flows through pad-holder (P) and then into chamber (A1) at reduced pressure. Reduction value is preset and depends on the load of spring (M1), which is normally set at 0.2 bar.

The second-stage regulator includes a diaphragm (D2), a spring (M2) and a valve (O2). The gas in chamber (A1) flows into chamber (A2) and then to utilities. Outlet pressure can be adjusted by means of ring nut (G).

Valve travel is limited by valve stop (F), thus limiting maximum regulator capacity. Whenever the demand for gas exceeds maximum regulator capacity, outlet pressure diminishes, thus activating underpressure slam-shut valve. Regulators are supplied for different maximum capacity values; values are indicated according to the colour code below:

25 St.cu.m/h	BLACK	Standard version
10 St.cu.m/h	BLUE	Upon request
6 St.cu.m/h	GREEN	Upon request

Increases in outlet pressure due to defective seal of regulator when closed cause relief valve (Vs) opening, thus releasing gas to the atmosphere.

The relief valve is also useful in compensating for increases in pressure due to solar heating in regulators mounted in outdoor individual domestic gas systems when capacity is zero.

Relief valve triggering value, corresponding normally to 10 mbar above outlet pressure, cannot be adjusted

as it depends on the load of spring (Ms).

In case of a non-standard triggering value being required, same should be specified upon ordering. On request, regulators can also be supplied without relief valves.

SETTING

In order to increase outlet pressure, rotate adjusting screw (G) clockwise, and anticlockwise in order to diminish it. Check pressure value by means of a master gauge with an appropriate scale or by means of a water column.

Overpressure slam-shut valve triggering can be adjusted by means of ring nut (Gb). Underpressure slam-shut valve triggering cannot be adjusted.

Regulators are factory tested and set as per the values shown on the data plate and specified by customer upon ordering.

SAFETY DEVICE

Outlet pressure in chamber (A2) is transmitted to chamber (Ab). Moving part (E) is held in place by overpressure spring (M3) and by the outlet pressure which opposes the action of underpressure spring (M4). Under these conditions, balls (S1) hold stem (T) firmly in position, which in turn, via balls (S2), prevents rotation of shaft (B). Finally, shaft (B) keeps slam-shut valve disc (Ob) open by means of the appropriate cam.

An increase or decrease in outlet pressure over or below admissible values causes moving part to travel, thus releasing balls (S1) and consequently shaft (B) so that valve (Ob) closes under the pressure of spring (Mb).

Overpressure triggering value can be adjusted by means of ring nut (Gb). Minimum pressure triggering value cannot be adjusted.

START-UP

Before start-up, make sure that all utility connections are securely closed and proceed as follows:

- A.** Close inlet shut-off valve and slightly open outlet valve.
- B.** Reset slam-shut valve.
In order to reset valve, slowly rotate lever (L) 90° anticlockwise and firmly press knob (R) all the way down.
- C.** Very slowly open inlet shut-off valve.
- D.** Wait until outlet pressure is stabilized and then slowly open outlet valve fully.

The above operations must also be carried out following triggering of safety devices and after necessary remedial action thereto.

For gas release piping

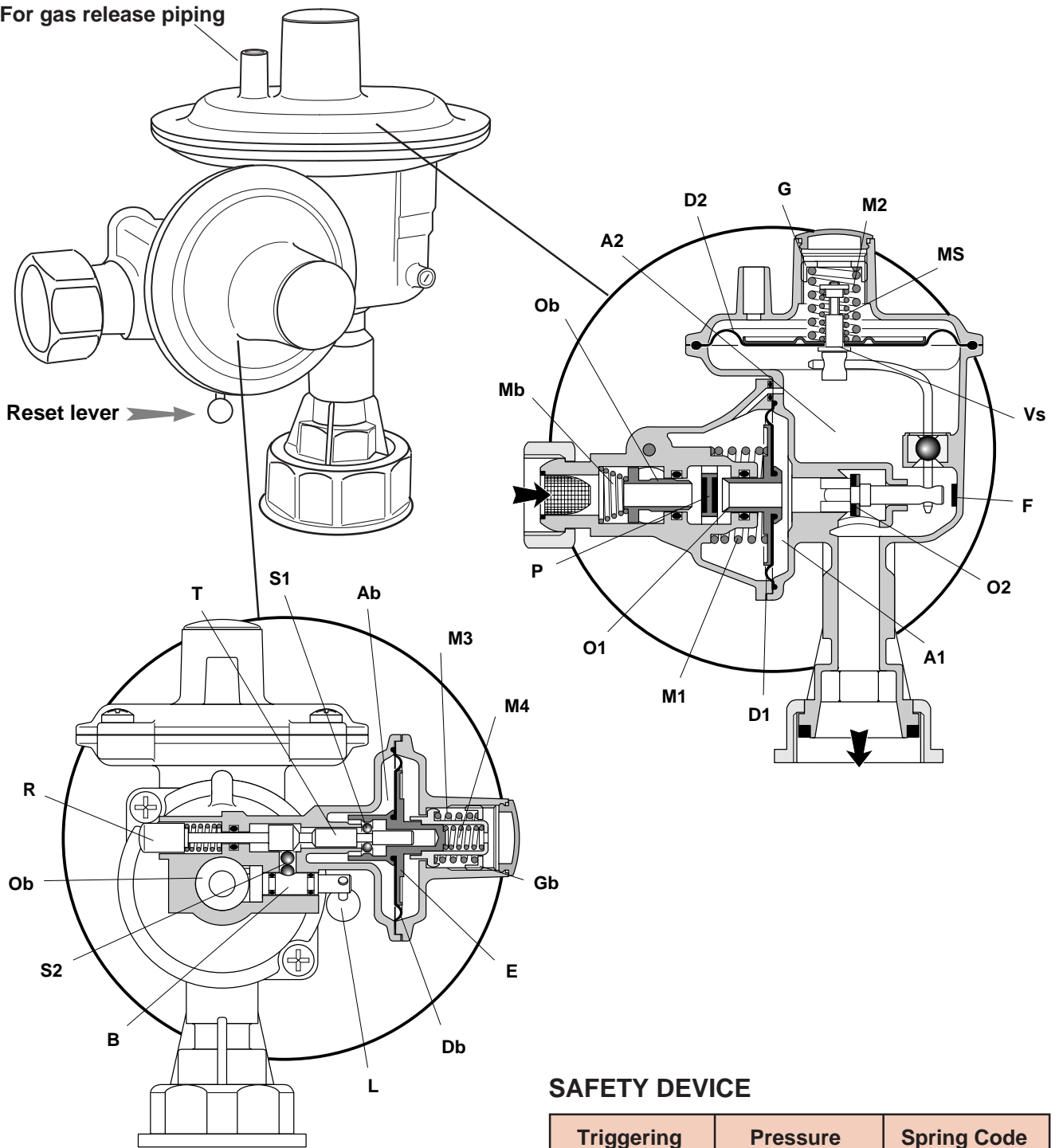

SAFETY DEVICE

Triggering Value	Pressure (mbar)	Spring Code No.
Overpressure	35 ÷ 40	0241760
Underpressure	12	0241740

MATERIALS

Connections	forged brass
Body	die-cast Zn + Al + Mg alloy
Covers	die-cast Zn + Al + Mg alloy
Diaphragms	Buna-N rubber impregnated cloth
Seals	Buna-N rubber

TECHNICAL DATA

Inlet pressure (max)	5 bar
Outlet pressure	30 mbar (max) 15 mbar (min)
Working temperature	-20°C to +60°C
Inlet connection	3/4"
Outlet connection	1-1/4"

CAPACITY TABLES

Outlet pressure (mbar)	Inlet pressure (bar)											Spring Code No.
	0.05	0.1	0.25	0.5	0.75	1	1.5	2	3	4	5	
15	4	12	17	25	25	25	25	25	25	25	25	—
20	5	12	17	25	25	25	25	25	25	25	25	0246690
30	—	10	17	25	25	25	25	25	25	25	25	—

Capacity in St.cu.m/h referred to natural gas with a specific gravity of 0.702.

For other gases, multiply the value by 0.595 for propane, 0.518 for butane, 0.755 for nitrogen and 0.744 for air.

CHARACTERISTIC CURVES - Set point pressure = 20 mbar

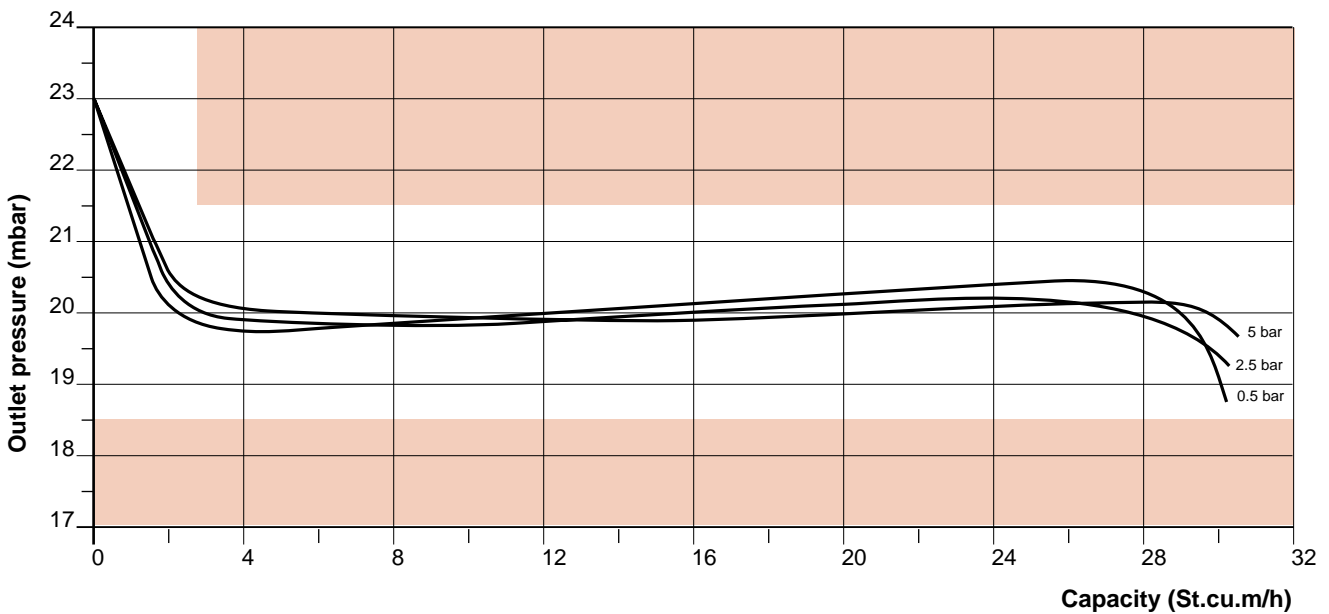

OUTLINE DIMENSIONS (mm)

Note: Dimensions are not binding.

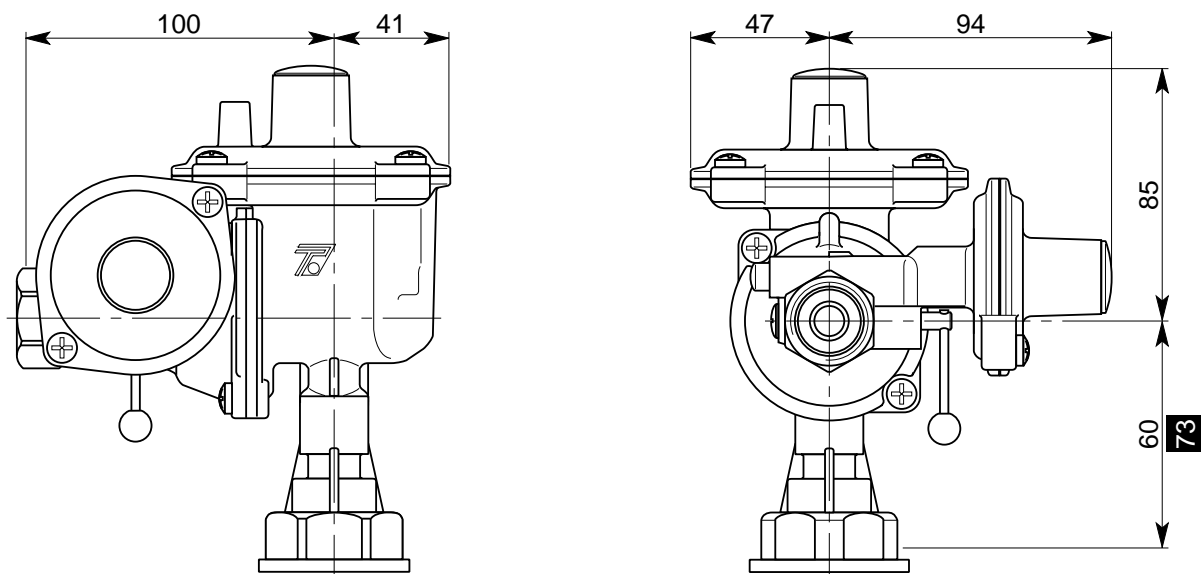

The value of 73 is only applicable to the R/25-1 model (metal-to-metal seal).